

Features

- 8 LEDs for Navigation, Landing and Beacon lights. Two modes:
 - Ultra bright mode (8,000 ~ 11,800 mcd per LED)
 - High brightness mode
 - Supports up to **16 LEDs** in ultra brightness mode
- Professional double blink strobe for rear Nav and strobe lights
- Li-Poly Low battery detection. Two modes:
 - Voltage monitor (selectable number of cells)
 - Time-out (selectable time periods)
 - Activation on first of above to occur option
- Low Battery warning:
 - Special LED blinking sequence (+ on board Red LED)
 - RC connector output pulse (for external system use, such as parachute)
- Li-Poly 1, 2, 3, 4, 5 or 6 (series) cells supported (up to 26v)
- RC Rx input to switch on / off
 - Landing lights activated coincident with landing gear
 - 2 way or 3 way RC switch supported
- RC Output (battery redundancy)
 - RC Rx back up power (BEC function to 4A burst)
 - Activation of external system in case of low battery
- Right out of the box use for easy in-field set up
 - On board DIP switches (PC status tool also available)
- Optional operation from external 5v, or 9v (up to 26v) supply
- Operational temperature: -30 °C to +85 °C
- RoHS, "green" compliant

Applications

- Scale RC Airplane / UAV / FPV
- Multi-copter and hybrid Aircraft
- RC Helicopter

Size, power and weight

- 80 x 50 mm controller unit
- 8 x LEDs with 1m (39") cables supplied
- 5mm LED diameter
- Power < 1W with x8 ultra bright LEDs
- All up weight is 87g (45g controller only)

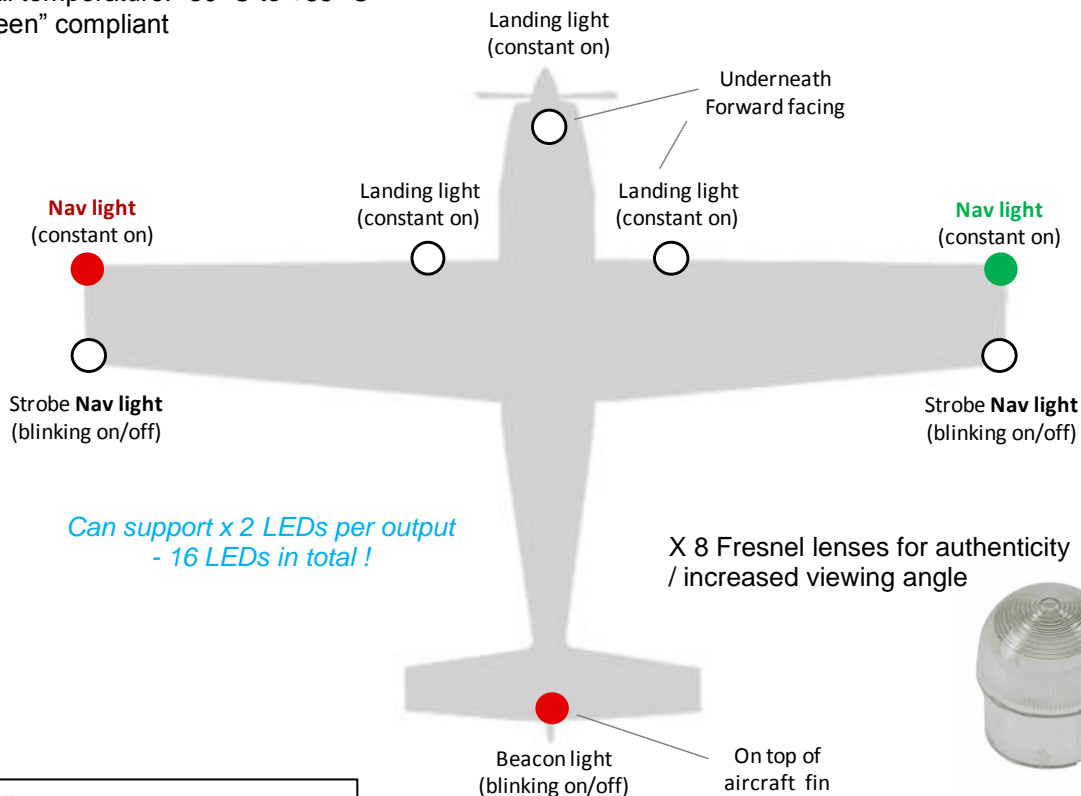

See more details at:
www.bluelight-tech.com/BL-NavLV.htm

1.0 Block Diagram

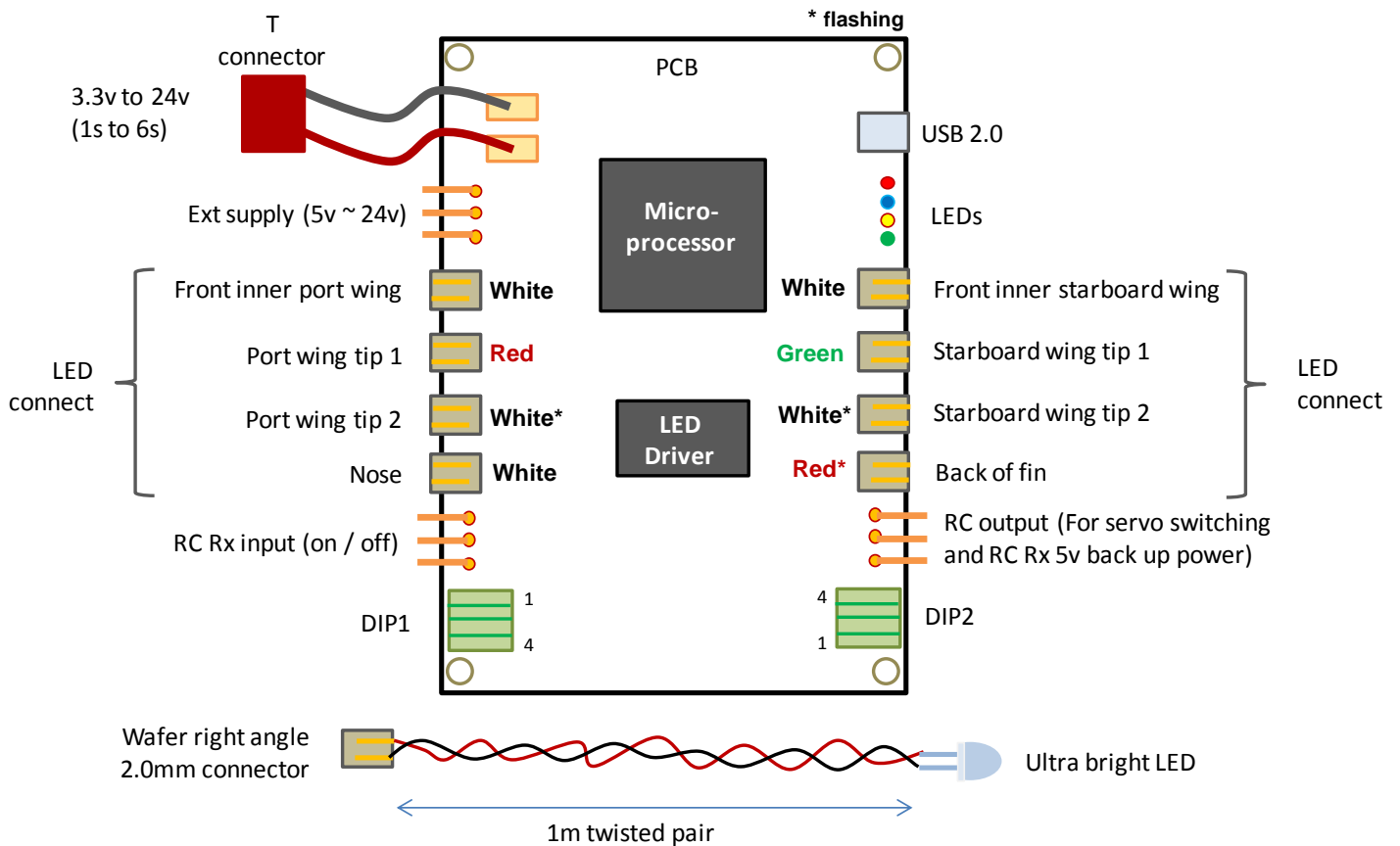

The PCB consists of the following connections:

- Main Li-Poly T connector for 1s to 6s battery connection (Black is ground)
- External supply for connection of, for example, a 9v battery
- x8 LED outputs (supports x2 LEDs per output)
- RC Rx input for on/off lights switching
 - Nav and Landing lights on / Nav lights only on : 2 way Rx Tx switch
 - Nav and Landing lights on / Nav lights on / All lights off : 3 way Rx Tx switch
- RC output for on/off of external device such as a parachute system or throttle cut-off
- x2 DIP switches for functionality setting (See section 2.0)

2.0 Connection and Switches

Connection is easily achieved by following the 16 steps here:

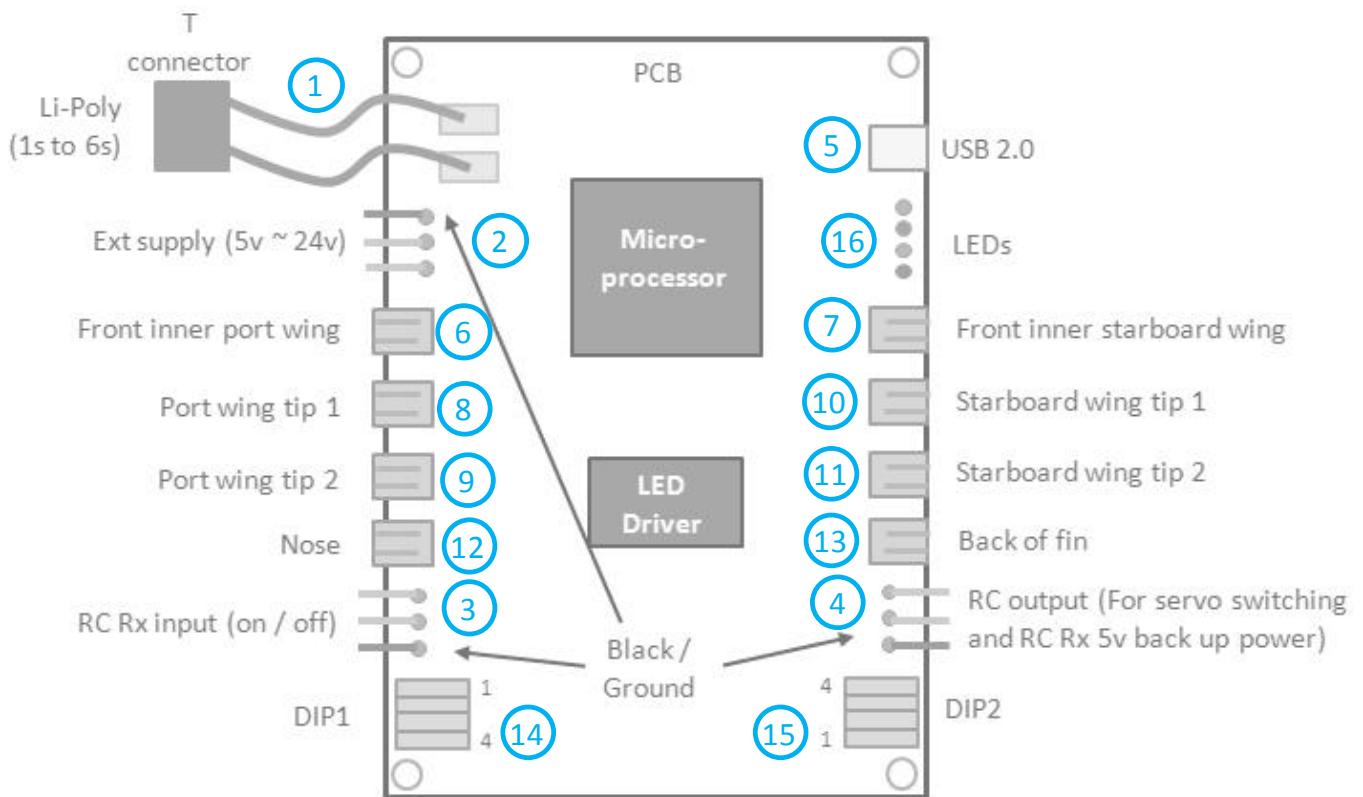

- (1) Connect the main Li-Poly battery here, maximum of 6 cells in series (6s).
- (2) If you plan to use the low voltage detect function it is advisable to connect an external power supply here. We suggest a standard 9V battery. Note that ground is on the T connector side of the PCB, and the voltage in the middle pin. This interface can take any voltage from 5v up to 26v. (Note that if this input voltage is less than the main LiPo voltage, the unit will not take power from it until the LiPo battery is flat. Conversely if the voltage is higher than the LiPo battery voltage the unit will be powered only from this input).
- (3) If you wish to connect an RC Rx signal in here you can. The default is to have all the LEDs active, but you can have the option to switch on / off as shown here:
 - a. Nav lights only / All lights on : 2 way Rx Tx switch
 - b. Nav lights only / All lights off / All lights on : 3 way Rx Tx switch
 Note that with no connection as per step (2), and Li-Poly battery drained the PCB will take power from this connector if necessary.
- (4) If you would like something to happen when the battery has been detected as being low you can connect this RC output signal (between 1ms and 2ms with 15ms period at 5v) to an external device, such as a parachute deployment servo. (The on / off level can be inverted with the DIP2). Note that if you have a battery connected as per step (2) this will serve as an RC Rx power supply (BEC) in case of main Li-Poly battery failure (5.2v nominally).
- (5) We provide a USB2.0 for firmware upgrade for future operationally different solutions to run on the same PCB. Please visit our website to check up on availability of different firmware. (Not needed for normal operation of this product).
- (6) thru to (13) connect up the LEDs to the locations as shown on the front cover diagram.

(14) → **DIP1**: Select the set-up options you would like to implement on **DIP1**:

The BL-NavLV can be used to output a special sequence of flashes on all the LEDs to show that the battery is running low. This can be achieved with either the BL-NavLV checking the battery (**LowVBat Mode**) or by setting a time period after which you would like the LED indication to happen (**LowVtime Mode**). If both options are set the low battery LED sequence will be initiated when the first of these conditions is met.

Switches 1, 2 and 3 are used to select the number of cells you have in your Li-Poly battery. If these switches are all set to **off** it means the detection of a low voltage in **LowVBat Mode** is disabled.

SW 1,	SW2,	SW3		SW4
off	off	off	: LowVBat Mode Off	on : Bright mode 1 (Ultra brightness)
off	off	on	: 1 cell	off : Bright mode 2 (High brightness)
off	on	off	: 2 cells	
off	on	on	: 3 cells	
on	off	off	: 4 cells	
on	off	on	: 5 cells	
on	on	off	: 6 cells	
on	on	on	: LowVtest	

If all switches are set to **on** the LEDs will flash in the low battery test pattern so as to familiarize the RC pilot with the flashing sequence when a real low battery condition is met.

(15) → **DIP2**: Select the set-up options you would like to implement on **DIP2**:





Switches 1, 2 and 3 are used to select the time before the low battery level **LowVtime Mode** is activated. If these switches are all set to **off** it means the detection of a low voltage in **LowVtime Mode** is disabled.

SW1,	SW2,	SW3		SW4
off	off	off	: LowVtime Mode Off	off : RC out invert off (max pulse when low bat)
off	off	on	: 10 minutes	on : RC out invert on (min pulse when low bat)
off	on	off	: 15 minutes	
off	on	on	: 20 minutes	
on	off	off	: 30 minutes	
on	off	on	: 40 minutes	
on	on	off	: 50 minutes	
on	on	on	: 60 minutes	

Note: DIP2 SW4 also inverts the RC In function

Note: Any time between 5 mins and 4 hrs can be set using PC tool and advanced commands (see section 7.6.1)

(16) Verification of correct operation is achieved by checking the PCB LEDs

 RED LED	: LiPo below safe operational level when flashing on / off (LiPo damage may result) LiPo below very low level when constantly on (see last page of this document)
 BLUE LED	: System micro up and running (flashing on / off), otherwise off
 YELLOW LED	: LowVBat Mode selected: Flashing, longer time on than off : LowVtime Mode selected: Flashing, longer time off than on : Both LowVBat and LowVtime Modes selected: Symmetrical flashing : Test low battery alarm sequence: Fast symmetrical flashing
 GREEN LED	: Only LED mode (no battery monitoring): Off : Ultra LED brightness mode (Bright Mode1) selected when on : High LED brightness mode (Bright Mode2) selected when off

Note that these LEDs are tested once at system power up.

3.0 Example Connections for Electric Aircraft

3.1 Typical Connection (In low Voltage Detect Mode)

With this connection the battery low detect works on measuring the actual voltage on the main battery.

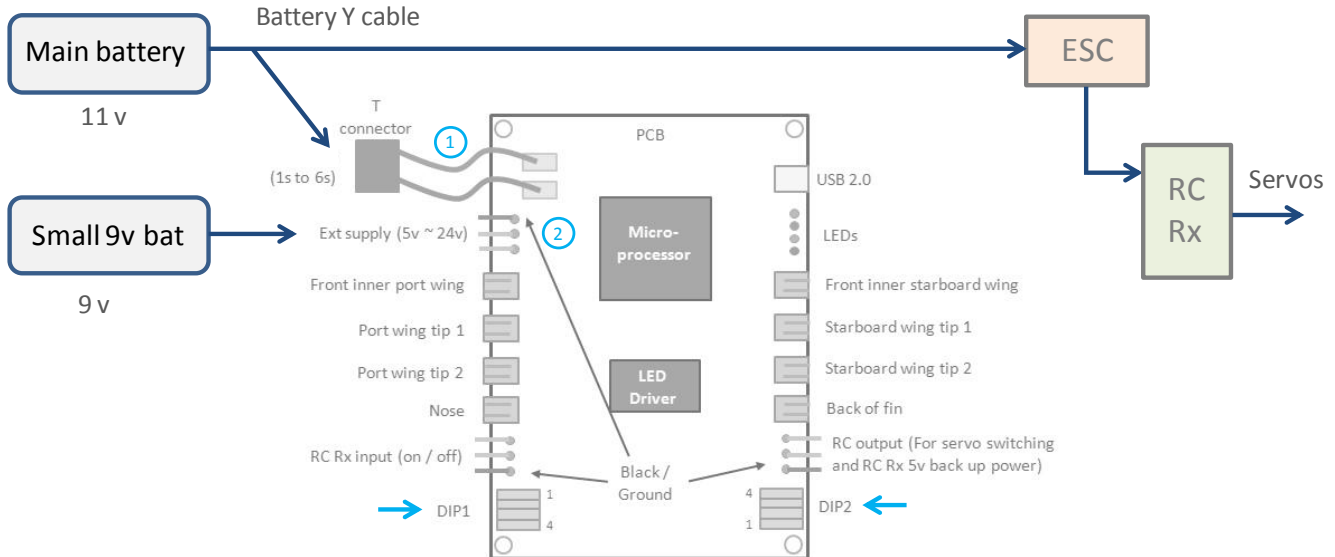

- (1) Connect the main Li-Poly battery here, maximum of 6 cells in series (6s).
- (2) Connect a small 9v battery here to power the LED/NAV PCB in case of main battery failure.
- Set DIP1 to the number of cells in your battery. For 3 cells, **1:off, 2:on, 3:on**, and **4:on** for ultra bright
- Set DIP2 to **all off**

3.2 Nav LED Connection Only (No low battery indication)

No voltage detect or timer. Only LED Nav lights operational

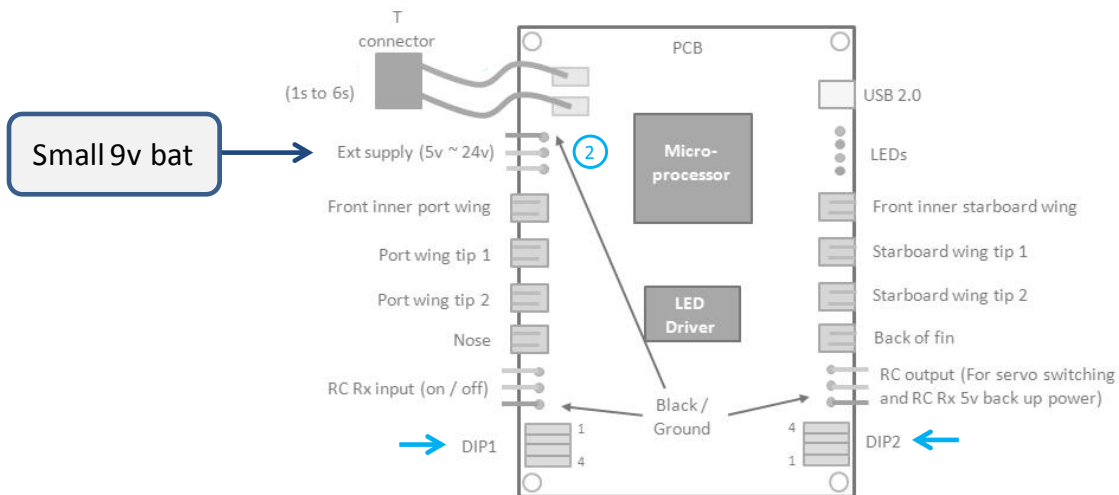

- (2) Connect only a battery or supply (typically 9v battery, or 5v / 6v supply in here)
- Set DIP1 to **1~3: off**, and **4:on** for ultra bright, or **off** for high brightness
- Set DIP2 to **all off**

3.3 Typical Connection (In Time Out Detect Mode)

With this connection the battery low detect works on a fixed time elapsing after being powered up.

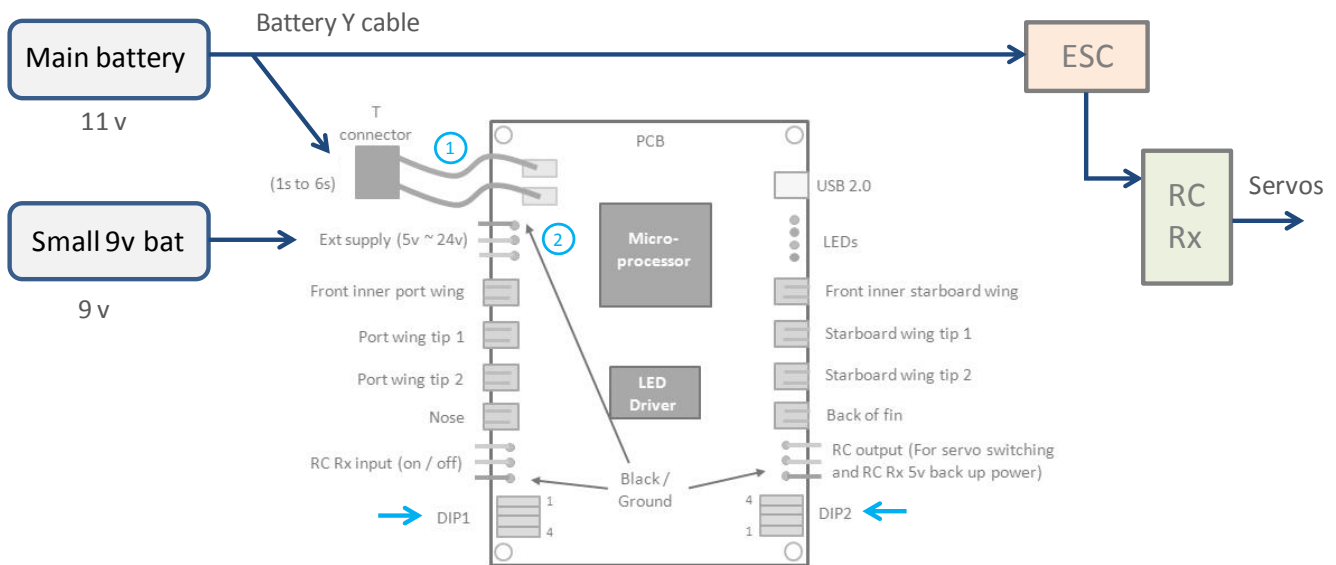

- (1) Connect the main Li-Poly battery here, maximum of 6 cells in series (6s).
 - (2) Connect a small 9v battery here to power the LED/NAV PCB in case of main battery failure.
- Set DIP1 to **1~3: off**, and **4:on** for ultra bright, or **off** for high brightness
 - Set DIP2 to the time-out time duration, eg for 20 minutes: **1:off, 2:on, 3:on, 4: off**.

3.4 Typical Connection (In Low Voltage AND Time Out Detect Modes)

It is possible to have the BL-NavLV perform its low voltage detect flashing sequence on whichever of the two events happens first: The detection of a low voltage on the main LiPo battery or a flight duration greater than a pre-set value.

The connection is the same as in 3.3 above but the DIP switches must be set up for both detect modes:

- Set DIP1 to the number of cells in your battery. For 3 cells, **1:off, 2:on, 3:on**, and **4:on** for ultra bright
- Set DIP2 to the time-out time duration, eg for 20 minutes: **1:off, 2:on, 3:on, 4: off**.

3.5 Battery Redundancy (For Servos and RC Receiver)

By having two LiPo batteries connected if one battery goes down (eg main battery below the voltage of the spare battery), no current will be taken out of it. Instead power will be taken from the good battery instead.

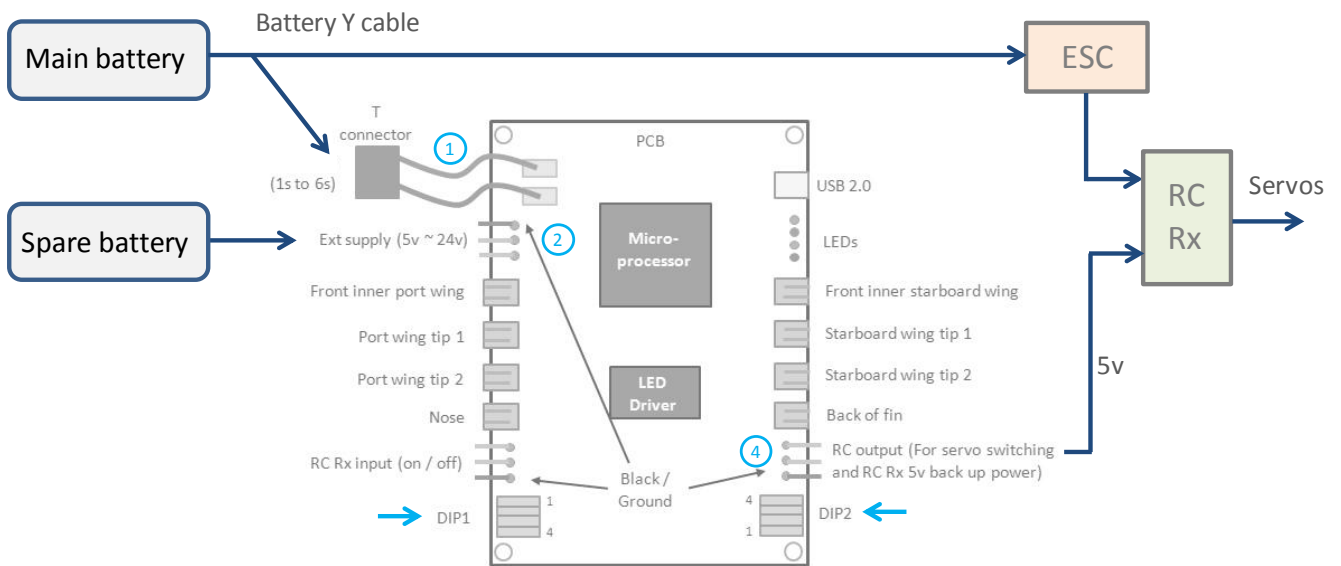

- (1) Connect the main Li-Poly battery here, maximum of 6 cells in series (6s).
- (2) Connect a secondary Li-Po battery here. If main battery goes down the second one will power the system, including the RC Rx and servos
- (4) Connect to RC Rx battery input or to any of the RC Rx unused outputs (MUST use a two wire cable for power / ground, ie with NO signal wire).

Note the BL-NavLV can supply 3A of continuous current (4A burst) from the spare battery to the RC output connector and onto the RC Rx and servos (BEC function). This is normally adequate for most multi-servo aircraft, but for larger multi-servo aircraft the servo power requirements should be checked.

- Set DIP1 to the number of cells in your battery. For 3 cells, **1:off**, **2:on**, **3:on**, and **4:on** for ultra bright
- Set DIP2 to **1~3: off**, and **4:on** to trigger chute with low RC signal, or **off**, to trigger on high RC signal

3.6 Parachute Deployment Mode (If battery low detected)

If the main battery goes low, a parachute servo is deployed via the RC output connection.

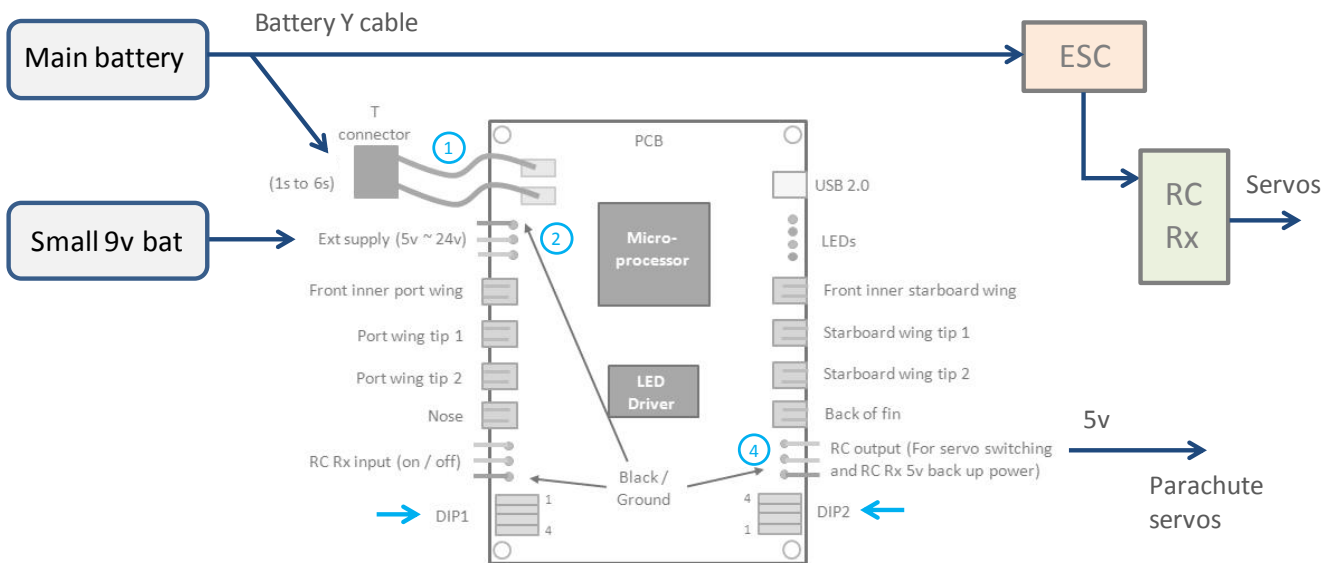

- (1) Connect the main Li-Poly battery here, maximum of 6 cells in series (6s).
 - (2) Connect a small 9v battery here to power the LED/NAV PCB and parachute servo in case of main battery failure.
 - (4) Connect a small deployment servo here (the RC output can support 3A current, so this will be no problem).
- Set DIP1 to the number of cells in your battery. For 3 cells, **1:off**, **2:on**, **3:on**, and **4:on** for ultra bright
 - Set DIP2 to **all off**

3.7 Nav / Landing Lights On / Off (With Optional Low Battery Detect Time Mode)

Simple connection to allow Nav. / Landing lights to be switched on and off as required. Note that if a Y cable is used the Landing lights can be switched on co-incident with the landing gear being deployed.

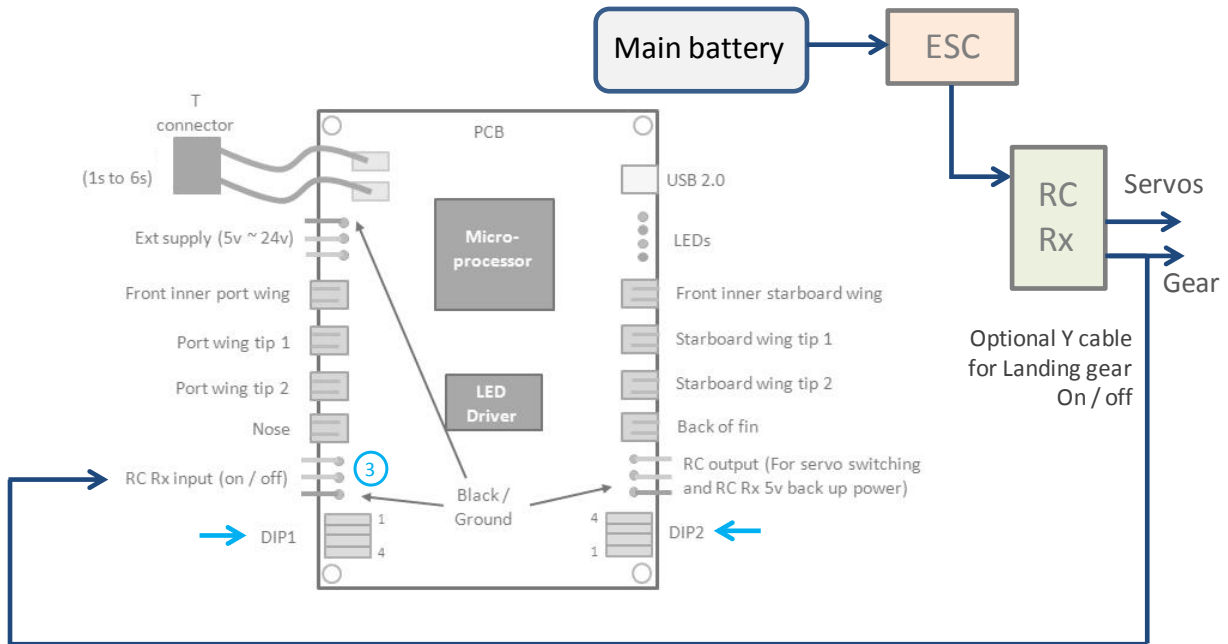

(3) Connect the RC Rx output to the RC Rx input (on / off) connector. The BL-NavLV will take power from this connector if no other battery is connected to it.

- Set DIP1 to **1~3: off**, and **4:on** for ultra bright, or **off** for high brightness
- Set DIP2 to **1~3: off**, and **4:off**, for normal RC Tx switch operation or **on** for inverse as shown here:

If you have a **TWO way switch** on your transmitter:

DIP 2 SW 4 position	RC Tx switch	Nav lights	Landing lights
Off	On (High pulse output)	On	On
	Off (Low pulse output)	On	Off
On	On (High pulse output)	On	Off
	Off (Low pulse output)	On	On

If you have a **THREE way switch** on your transmitter:

DIP 2 SW 4 position	RC Tx switch	Nav lights	Landing lights
Off	On (High pulse output)	On	On
	Mid (Mid pulse output)	Off	Off
	Off (Low pulse output)	On	Off
On	On (High pulse output)	On	Off
	Mid (Mid pulse output)	Off	Off
	Off (Low pulse output)	On	On

Note, if you wish to display the low battery flashing sequence after a set period of time simply:

- Set DIP2 Switches 1~3 to the time period, eg for 20 minutes: **1:off, 2:on, 3:on**.

3.8 Nav / Landing Lights On / Off (In low Voltage Detect Mode)

Simple connection to allow Nav. / Landing lights to be switched on and off as required. Note that if a Y cable is used the Landing lights can be switched on co-incident with the landing gear being deployed.

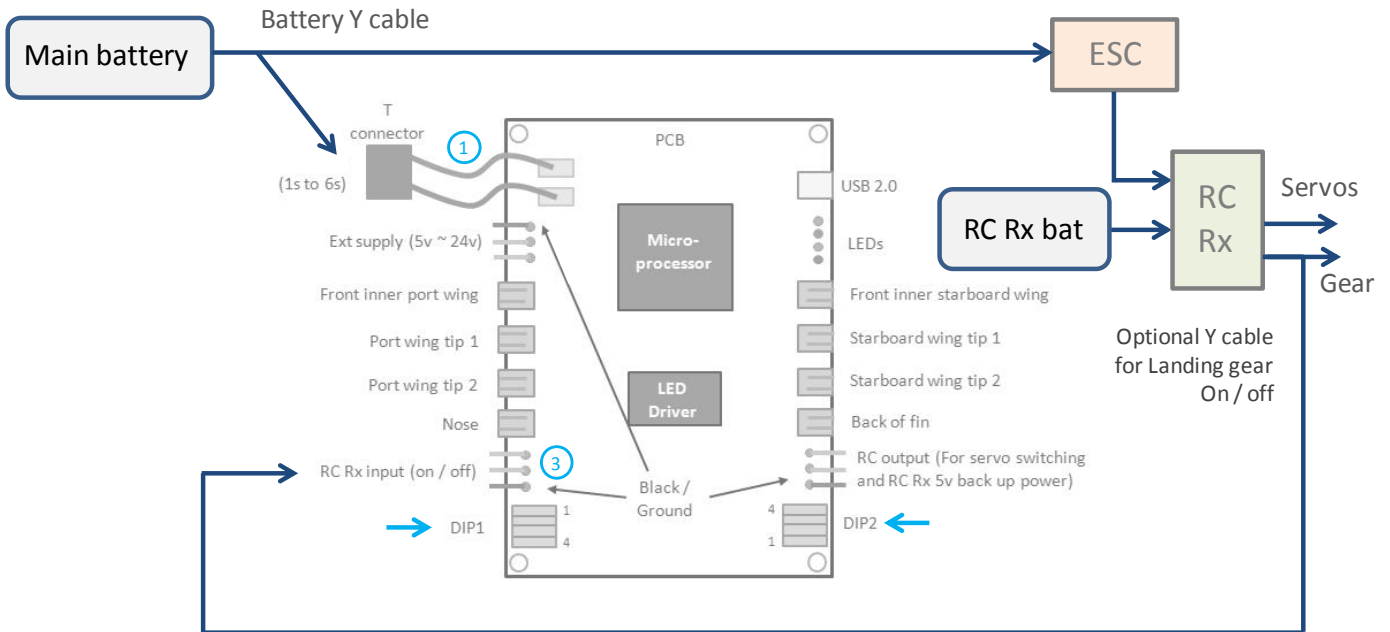

- (1) Connect the main Li-Poly battery here, maximum of 6 cells in series (6s).
- (3) Connect the RC Rx output to the RC Rx input. The BL-NavLV will take power from this connector if no other battery is connected to it. Note the optional RC Rx bat connected to the RC Rx. If the main LiPo battery goes down it may go down very quickly.

- Set DIP1 to 1~3: **off**, and 4:**on** for ultra bright, or **off** for high brightness
- Set DIP2 to 1~3: **off**, and 4:**off**, for normal RC Tx switch operation or **on** for inverse as shown here:

If you have a **TWO way switch** on your transmitter:

DIP 2 SW 4 position	RC Tx switch	Nav lights	Landing lights
Off	On (High pulse output)	On	On
	Off (Low pulse output)	On	Off
On	On (High pulse output)	On	Off
	Off (Low pulse output)	On	On

If you have a **THREE way switch** on your transmitter:

DIP 2 SW 4 position	RC Tx switch	Nav lights	Landing lights
Off	On (High pulse output)	On	On
	Mid (Mid pulse output)	Off	Off
	Off (Low pulse output)	On	Off
On	On (High pulse output)	On	Off
	Mid (Mid pulse output)	Off	Off
	Off (Low pulse output)	On	On

Default with no input is all lights enabled

Note, if you wish to display the low battery flashing sequence after a set period of time simply:

- Set DIP2 Switches 1~3 to the time period, eg for 20 minutes: **1:off, 2:on, 3:on**.

4.0 Example Connections for Gas Aircraft

4.1 Fuel Low based on Flying Time Detect Mode

The Low Voltage Detect flashing sequence can be initiated for gas aircraft simply based on the flying time. The flight duration is used in this mode so this can be assumed to indicate a low fuel condition.

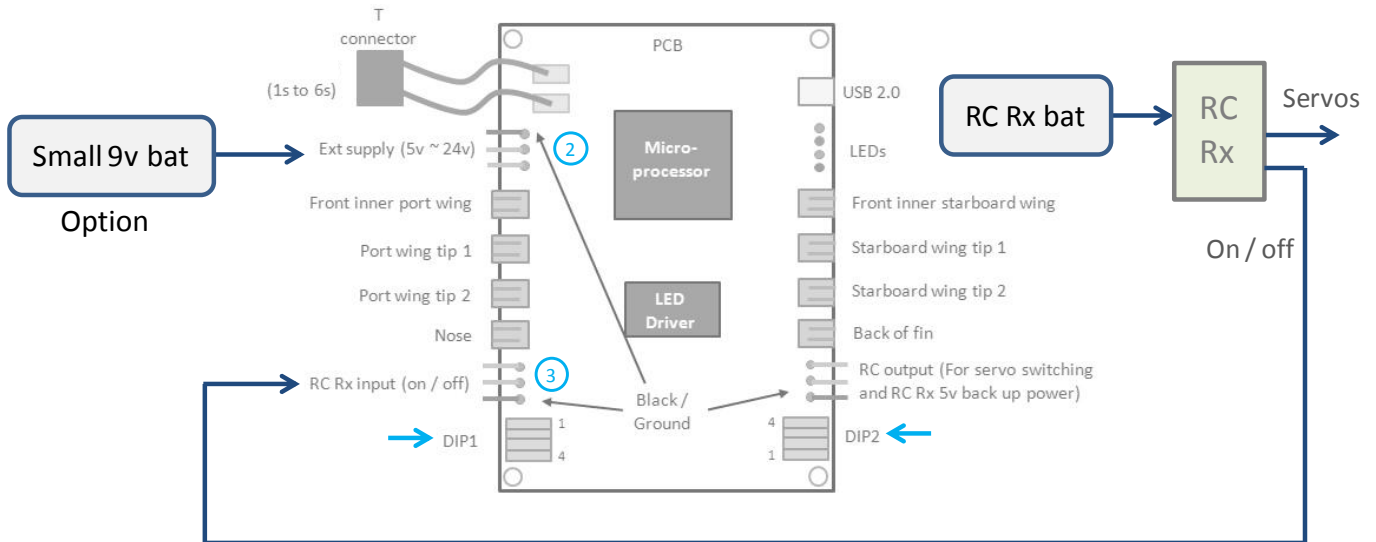

(2) The small 9v (or any 5v~26v) battery is an option if you don't want to drive the unit from the main supply (via the on/off switch in the example shown above).

(3) Connect an input from your RC Tx switch such as on / off, or gear down or any spare switch.

→ Set DIP1 to **1~3: off**, and **4: on** for ultra bright, or **off** for high brightness

→ Set DIP2 to the time-out time duration, e.g. for 30 minutes: **1: on, 2: off, 3: off, 4: off**.

4.2 Redundant Battery with Low Battery Voltage Detect Mode and Lights on/off

Connection with spare battery and detect if main battery goes low. Also shown is connection of lights switch.

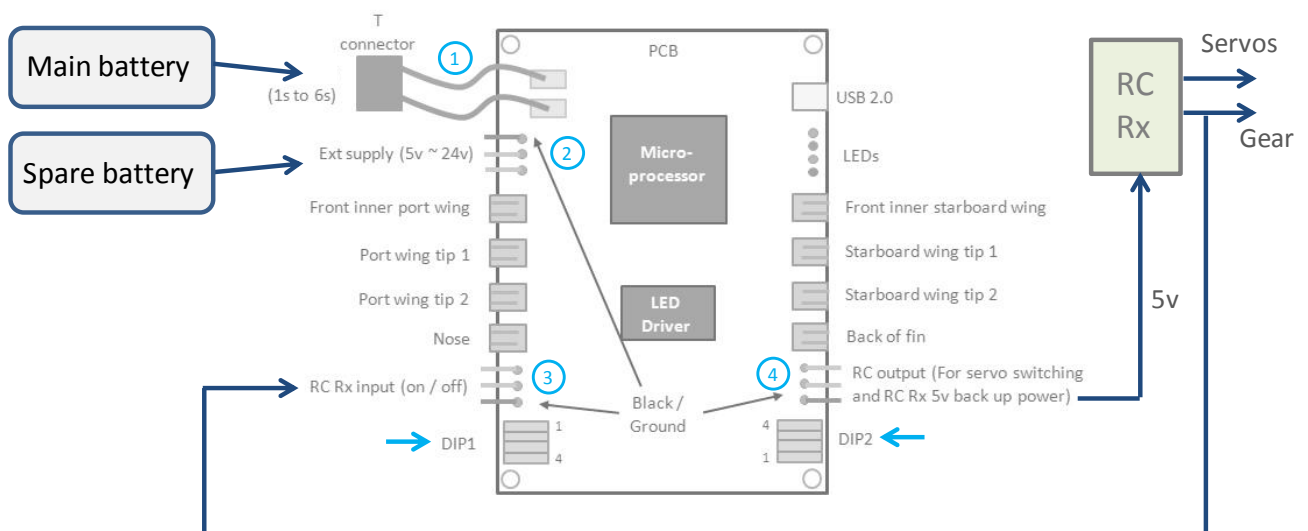

- (1) Connect the main LiPo electronics battery here, minimum 5v, maximum 12v.
- (2) Connect a secondary battery here. If main battery goes down the second one will power the system, including the RC Rx and servos
- (3) Connect an input from your RC Tx switch such as gear down (via Y cable), or any spare switch
- (4) Connect to RC Rx battery input or to any of the RC Rx unused outputs (MUST use a two wire cable for power / ground, ie with NO signal wire).

Note the BL-NavLV can supply 3A of continuous current (4A burst) from the spare battery (or main LiPo battery, whichever is the greater voltage) to the RC output connector (4) and onto the RC Rx and servos. This is normally adequate for most multi-servo aircraft, but for larger multi-servo aircraft the servo power requirements should be checked.

- Set DIP1 to the number of cells in your battery. For 2 cells, **1:off, 2:on, 3:off**, and **4:on** for ultra bright
- Set DIP2 to **all off**.

5.0 Low Volt (LowVBat Mode) or Time out (LowVtime Mode) flashing sequence

The unit can be tested to see the warning (either **LowVBat Mode** or **LowVtime Mode**) flashing sequence by setting:

- DIP1 to **all on**.

The sequence for all LEDs is:

Sleep 2s, on 200ms, off 240ms, on 200ms, off 240ms, on 200ms, and repeat

(Note, if a 3 way switch is used, the all LEDs off position will also switch this test sequence off)

6.0 Battery Requirements

6.1 Simple 9V Battery

The BL-NavLV requires around 1 Watt of power to operate (Assuming it doesn't power any external RC Rx or servos). Hence a 9v battery (typically with 550 mAh rating) will last for:

$0.55 / (1 / 9) = 5.0 \text{ hours}$ with LEDs in Ultra bright mode.

6.2 Small 2s LiPo Battery

With a 7.4v 2s, 1000 mAh LiPo will last for:

$1.0 / (1 / 7.4) = 7.4 \text{ hours}$ with LEDs in Ultra bright mode

6.3 Medium 3s LiPo Battery

With an 11.1v 3s, 2200 mAh LiPo will last for:

$2.2 / (1 / 11.1) = 24.4 \text{ hours}$ with LEDs in Ultra bright mode

7.0 Advanced Features

7.1 Snooze Mode

When you're flying and the alarm for low battery activates (either via the time-out mode or the low LiPo battery voltage detection), it may be that you wish to have the Navigation and Landing lights operate as normal for the landing: Simply move the switch to a new position and the alarm sequence will be disabled for a period of 5 minutes (by default). This parameter can be changed via the advanced commands, see section 7.6.1. Note that when Snooze mode exits, the warning flashing sequence will again be activated if you were in time-out mode, or in low voltage detect mode, if the low battery condition is still present.

If you do not wish to toggle a switch to disable the alarm flashing sequence you can have the BL-NavLV automatically do this for you after a certain time (10 seconds by default). You can program this *Auto Snooze* feature via the advanced commands, or if you don't wish to connect to a PC you can also program this in the following way:

- 1) Remove all power to the BL-NavLV unit, and set the DIP switches of both DIP 1 and DIP 2 to all **ON**
- 2) Power up the BL-NavLV, then set the DIP switches to your normal desired positions.

(If you wish to change the Auto Snooze time from the 10s default, you will again need to refer to the advanced commands (SzAT) in section 7.6.1).

To again de-activate this *Auto Snooze* mode feature simply repeat the above but with all DIP 1 and DIP 2 switches to **OFF** prior to power on.

7.2 Connection of more LEDs

For pilots interested in specific configurations it is possible to connect another LED in parallel. This is achieved by simply connecting another LED in parallel to an existing one with your own special cable. For example you may wish to add additional green and red navigation lights. **No more than two LEDs per output otherwise damage may occur to the PCB (see note below)**. Any additional LEDs will operate at the same brightness level as the originals.

White and Green LEDs

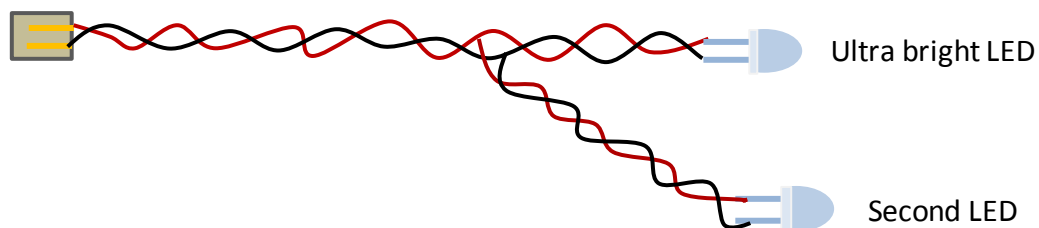

Red LEDs

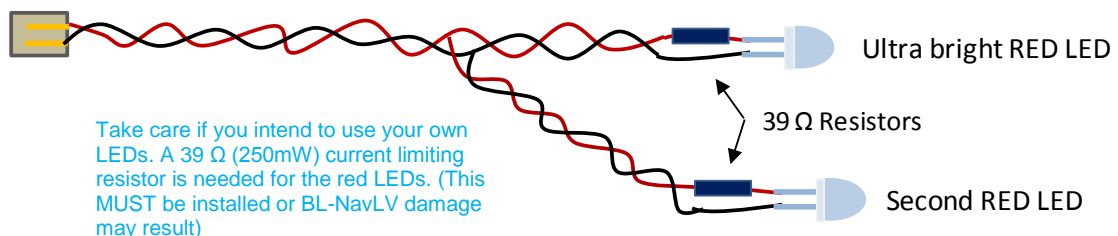

Take care if you intend to use your own LEDs. A 39 Ω (250mW) current limiting resistor is needed for the red LEDs. (This MUST be installed or BL-NavLV damage may result)

Simply splice in an additional LED as shown above. Note that the red LEDs have a small current limiting resistor close to the LED itself.

Additional sets of LEDs and connectors can be bought from bluelight-tech.com website.

7.3 LED lead lengths changes

The length of the twisted pair cables can be reduced or increased as desired. There is no real practical limit to the length, but we suggest no longer than 4 meters.

7.4 Alternative Connections

It is perfectly safe to swap LEDs, i.e. any LED can be plugged into any controller board LED output connector.

7.5 Operation with LiPo batteries larger than 6 cells

If you have more than 6 cells, you can still use the BL-NavLV with all its features. Each LiPo has a balance connector which outputs the voltage on each of its internal cells. You can make up a special cable to allow just one of the cells' voltage to be monitored (one cell connection + ground). Then set the BL-NavLV up with 1 cell selected on DIP1. You will also need to supply an alternative power source to the BL-NavLV, such as 5v or higher into the Ext Supply input or into the RC Rx input.

7.6 Optional PC Status and Advanced Set-up Tool

If you wish to check the status of the BL-NavLV unit, including voltage levels of batteries you connect to it you can use the PC status software. It will also aid in setting up the unit to your exact requirements. Supports Windows platforms only (XP, Vista, 7 and 8). Runs on 64 bit machines (in 32 bit mode). Requires .NET framework.

The tool is available free from the bluelight website (www.bluelight-tech.com).

The main *Status* screen is shown here for information.

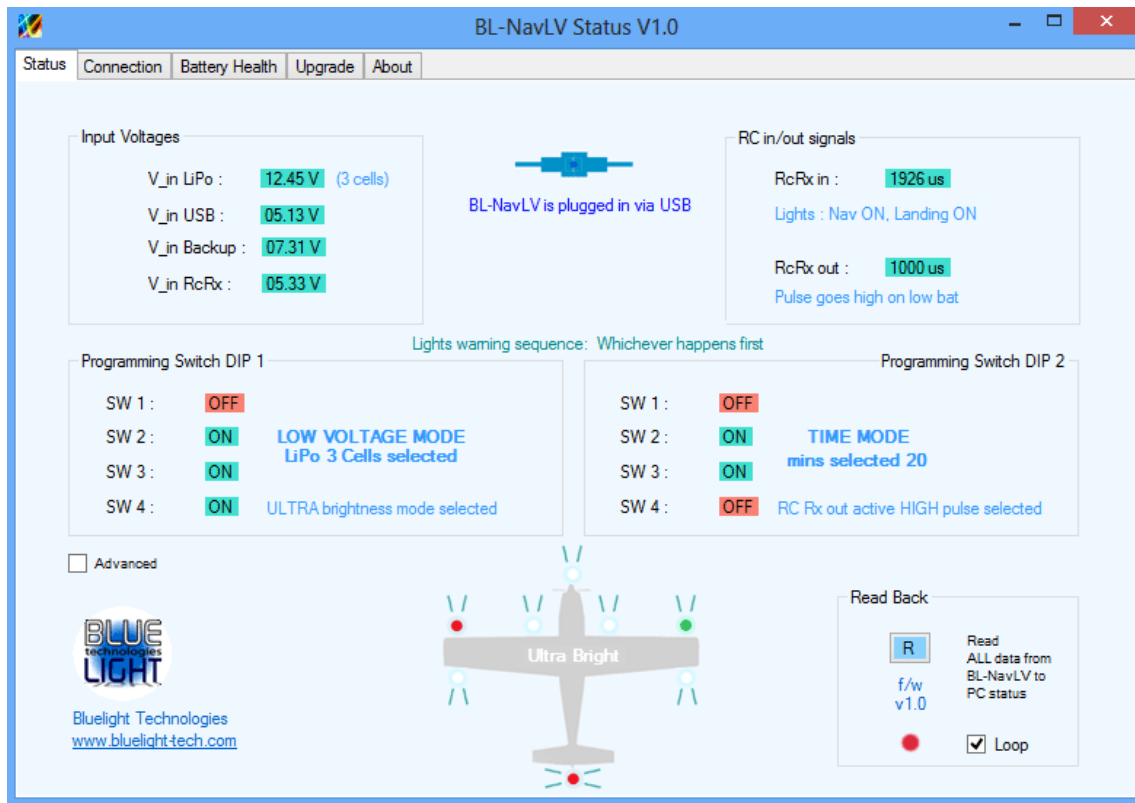

USB / PC Status tool – Status tab

The aircraft graphic lights will actually blink as the real BL-NavLV will operate if connected via USB and set in loop mode (constantly getting data from the BL-NavLV module). Hence the complete system can be checked out via USB prior to connecting any real LEDs.

Please take care to ensure an external power source is connected to the BL-NavLV controller board (if the LEDs are connected) prior to plugging into the PC USB port. Due to limited power output from the USB port incorrect functionality can occur.

Two further tools you may find useful are also provided as shown on the next page.

This tool will be updated to allow further changes in the future. Hence an *upgrade* tab page is also provided to allow the BL-NavLV firmware to be upgraded as required. Please see our website for more details.

Other tools that may be of interest are as shown here:

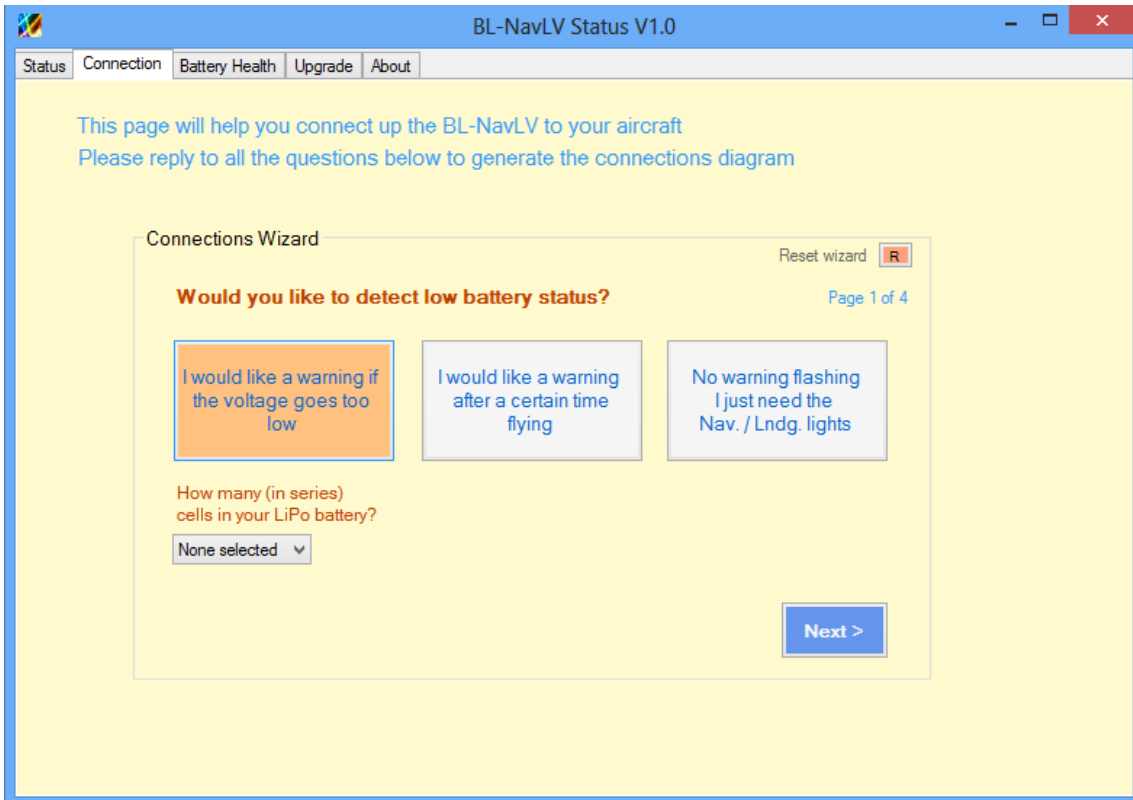

USB / PC Status tool – Connection Wizard tab

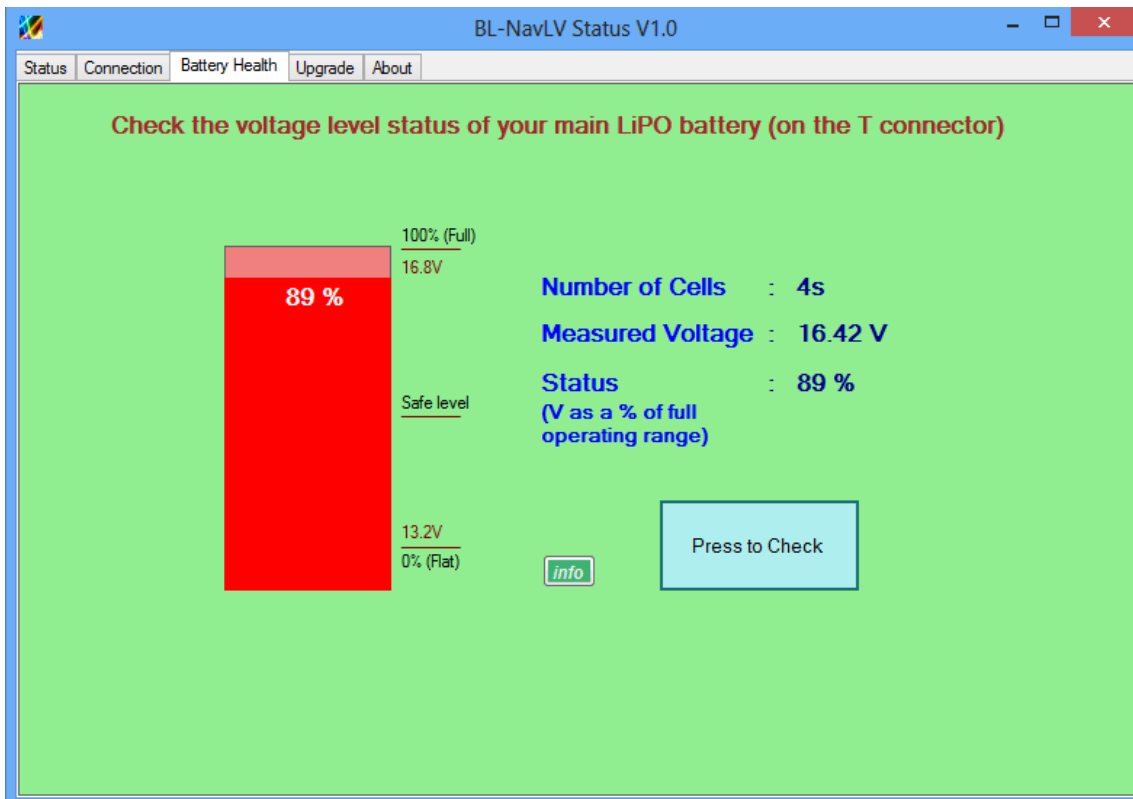

USB / PC Status tool – Battery Health tab

7.6.1 Optional PC Status Tool – Advanced Commands

At the bottom left of the *Status* tab page you will see an *advanced* check box option. Clicking this makes the following screen visible:

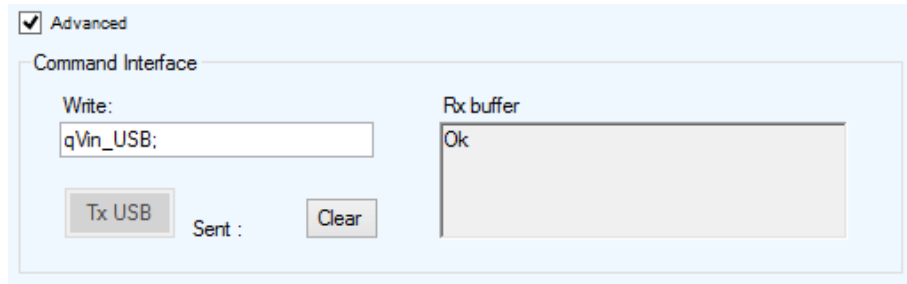

This is the command interface. Certain functionality of the BL-NavLV unit can be customized with special commands. Also status commands can be sent to glean specific information from the unit.

If information is to be written into the unit the following command format is to be used:

To set a parameter: e.g. for the V_trig command : **$V_trig = 3.41;$**
 To read back a parameter, e.g. for V_trig : **$qV_trig;$** (response is $V_trig = 3.4100;$)

Set Command	Query command	Comments
<i>PC tool Advanced Commands</i>		
V_trig	$qV_trig;$	Sets / reads back the low battery level (per cell) to trigger the low battery flashing sequence (default 3.4V per cell).
T_trig	$qT_trig;$	Sets / reads back the time delay (in minutes) prior to triggering the low battery flashing sequence. (If programmed to a value between 5 and 240 minutes it will override the values obtained via the on board switches). If previously set up can set to 0 to cancel. (BL-NavLV PCB switches MUST be set in <i>LowVtime</i> mode)
PWM_period	$qPWM_period;$	Sets / reads back the output PWM period in us (default 15000us). Practical limits should be between 20000us and 1400us
Hyst	$qHyst;$	Sets the hysteresis in the trigger point detect voltage (limits 0 to 10% of the single cell low voltage trigger level). Default is 1%
SzTime	$qSzTime;$	Sets / reads back the time (in seconds) the low battery alarm flashing sequence is temporarily disabled after entering snooze mode. The alarm will again be activated on exit if set on a time out, or if set on a low voltage detect, only if the low voltage condition is still present. (Default is 5 minutes)
SzAuto	$qSzAuto;$	Sets / reads back the Automatic Snooze function setting. 1 if set (enabled) 0 if not
SzAT	$qSzAT;$	Sets / reads back the Automatic Snooze function timer. I.e the Alarm flashing sequence will automatically be disabled after this time (in seconds – default is 10 seconds). Note it will come on again after <i>SzTime</i> seconds. Limits are between 1 second 10 minutes (600 seconds)
n/a	$qAlarm;$	Reads back the Alarm status (1 if alarm has been set)
n/a	$qSnooze$	Reads back if the unit is in Snooze mode (1 if yes)
n/a	$qVin_LiPo;$	Reads back the T connector connected battery voltage level
n/a	$qVin_USB;$	Reads back the USB voltage level
n/a	$qVin_Backup;$	Reads back the backup connected battery voltage level
n/a	$qVin_RcRx;$	Reads back the RCRx connected battery voltage level
<i>PC tool System Commands</i>		
EERASE	n/a	Erases the entire EEPROM contents (set to factory defaults at new power up)
AlarmDis	n/a	Temporarily disables the flashing alarm completely (need to power cycle to enable again)

8.0 LiPo Battery low Warning Trigger Level

LiPo batteries consist of multiple single cells (3.7 V) connected together in series. This discussion therefore focuses on a single cell case. It is then an easy matter to just multiply the numbers up depending on how many cells you actually have in your LiPo battery.

LiPo batteries have different discharge characteristics depending mainly on the **C** rating, but also on the operational temperature, and to a certain extent on the manufacturer. A typical chart of the voltage level of the cell and the charge remaining is shown here for a particular 4200mA battery:

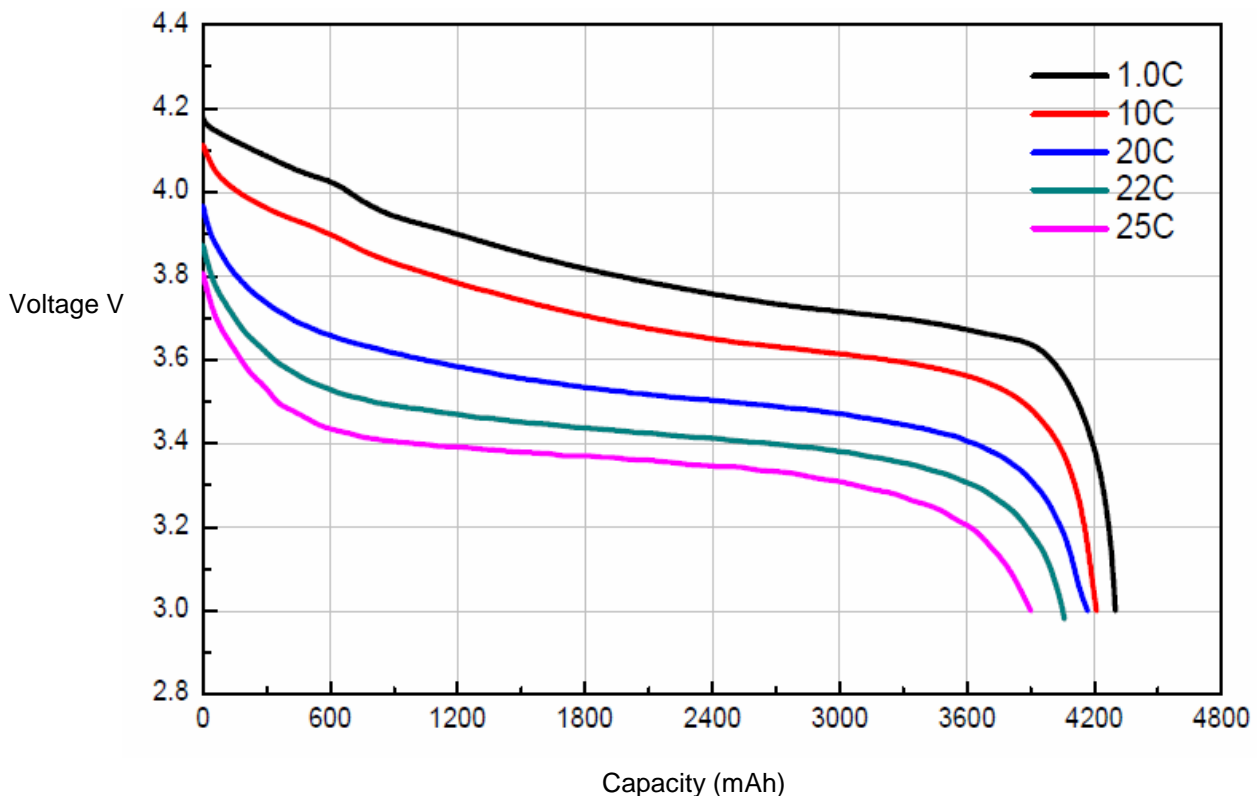

As you see, the cell capacity goes down, almost to a plateau, then falls off sharply at the right hand side “Knee” as the voltage falls. So typically the LiPo can be charged up to about 4.2v and discharged down to around 3V. However the battery will always have a minimum discharge level. In other words, a level where you must not discharge the battery further otherwise the battery will become damaged and no longer able to retain its full charge after the next charge cycle. A typical number talked about is to run the battery down to 20% charge remaining, i.e. to use only 80% of its total charge. However each individual has his or her own preference for a multitude of reasons.

The BL-NavLV has by default a level of 3.4V as the level at which a warning is issued (special LED flashing sequence, and controller PCB red LED flashing). This 3.4V per cell threshold can be changed with the BL-NavLV PC tool to any voltage level desirable. See section 7.6.1 above. Once a trigger condition has been found the normal LED operation will only be started again after the voltage rises to at least the trigger level + a hysteresis value, which by default is set to 1% of the trigger level (so at 3.434V per cell nominally). This hysteresis value can also be changed with the appropriate advanced command.

Note that voltage is not the only means to measure a LiPo cell capacity, but it is a reasonably good approximation for most cases. Actually measuring the current taken over time will give a very good indication of the charge remaining, and therefore flight time remaining; this especially true if temperature is also taken into consideration. If you wish to trigger the BL-NavLV flashing sequence once an external charge measuring equipment measures charge then a control voltage with trigger below the (nominally 3.4V per cell) threshold voltage can simply be input to the BL-NavLV T connector instead of the actual LiPo battery.

9.0 Electrical Specifications

Feature	Electrical / Mechanical specification
LEDs (Nav / Landing / Warning) -All ESD protected to 415 KV	
Red LED	8,000 mcd typical luminous intensity @ 20mA (2θ/2 Viewing angle 30°)
Green LED	14,400 mcd typical luminous intensity @ 20mA (2θ/2 Viewing angle 30°)
White LED	11,800 mcd typical luminous intensity @ 20mA (2θ/2 Viewing angle 15°)
LED outputs (Max current)	40mA per channel (Absolute max power 250 mW per channel)
Electrical Interfaces - All ESD protected to 415 KV	
T Connector (input V)	Nominally min 5v to absolute max 26.2v
Ext Supply (input V)	Nominally min 5v to absolute max 26.2v
RC Rx input on / off (input V)	Nominally min 5v to absolute max 7.5v as power input (input to ADC)
RC output, (output V)	5.2V (max 3A continuous, 4A bursts, then 5v) BEC function
RC output, (input V)	Nominally min 5v to absolute max 26.2v as power input
USB	Mini USB V2.0 (absolute max 6.5v)
Signal Interfaces	
RC Rx input PWM (input)	Nominally min 1 ms, max 2 ms, 15ms period (0v to absolute max 7.5v square wave)
RC output, (output)	Nominally min 1 ms, max 2 ms, 15ms period (0v to 5.2v square wave)
LED indicators	
Red : Battery Warning	Flashing: LiPo in danger zone, running low. Continuously on: LiPo voltage very low state!
Blue: System Operational	Intermittent flashing. System micro up and running
Green: Mode indication	Continuous: Ultra bright mode, Off: High brightness mode
Yellow: Low bat detect mode	More on than off : LowVolt mode, more off than on: LowTime mode, symmetrical on/off: Both modes
DIP Switches	
DIP1 (4 switches)	LowVBat mode cell count and LED brightness mode
DIP2 (4 switches)	LowVTime mode duration programming and RC Rx input / RC Rx output invert
Operational and Conformance	
IEC	Designed to meet IEC 61000-4-2 level 415 kV (air discharge) 8 kV (contact discharge)
MIL	Designed to meet MIL STD 883G - Method 3015-7: class 3 Human body model
RoHS	Compliant
Temperature	-30 °C to +85 °C
Protection	PCB-A is sprayed with an acrylic coating for protection against fingerprints / grease
Flashing sequence	Meets FAA Doc. No. 5066, 29 FR 18291 (Incl. Amdts. up to 25-41, 42 FR 36970, July 18, 1977)

Note : If using the BEC output function, cannot have only RC Rx input (5V) as input power source. Must have a power source of minimum 6V, preferably higher. Only 3A for input voltages above 12v.

Cells	1	2	3	4	5	6
High Level (V)	4.2	8.4	12.6	16.8	21.0	25.2
Low level (V)	3.7	7.4	11.1	14.8	18.5	22.2
Very Low (V)	3.3	6.6	9.9	13.2	16.5	19.8
Trigger V (default)	3.4	6.8	10.2	13.6	17	20.4

Note1 : By default the trigger point for low battery level detect is 3.4V per cell. This to protect the LiPo battery. Trigger level value can be changed with advanced command (see section 7.6.1 of this document)

Note2: Hysteresis at the trigger point value set to 1% by default. (Can change with advanced command)

Note3 : LiPo battery voltage measurement error, max ± 0.2%

WARNING:
These LEDs are very bright, please avoid direct close-up eye contact

See <http://www.bluelight-tech.com/BL-NavLV.htm> for more information
 Contact: info@bluelight-tech.com

All content copyright © 2013 Bluelight Technologies Co. Ltd.
 199 / 206 Moo3, Soi Tha It, Rattanaithibeth Road,
 Muangnonthaburi, Nonthaburi 11000.